

# 3GHz Coaxial Connectors

## Top Entry BNC Connector with Protective Sleeve

Part Number C-SX-119

### General Description

The C-SX-119 Precision 75Ω BNC top entry PCB mounted connector with a protective insulator sleeve around the centre contact. The centre contact is a thickness of 0.93mm.

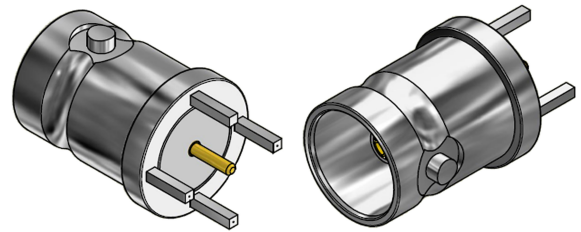

### Electrical Specification

Impedance:	75Ω
Frequency Range:	0-3GHz
Working Voltage:	500Vrms
Dielectric Withstanding Voltage:	1500Vrms
Reflection Factor (VSWR):	1.04 <sup>(max)</sup> DC - 1.5GHz 1.11 <sup>(max)</sup> 1.5 - 3GHz
Contact Resistance:	Centre contact 1.5mΩ Outer contact 1.0mΩ
Insulation Resistance:	>5000M Ω
Connector Type:	Female
Materials	
Centre Pin:	Phosphor Bronze/ 10 μ"Au
Metal Parts:	Brass / Ni
Insulators:	PTFE
Environmental	
Temp Range:	-65 to +85°C
Mating Cycles	250
Processing	
Maximum wave and hand soldering temperature	265°C

### Features

- Precision 75Ω BNC Connector
- Designed for HD SDV applications
- Low profile feature allows for high wiring densities

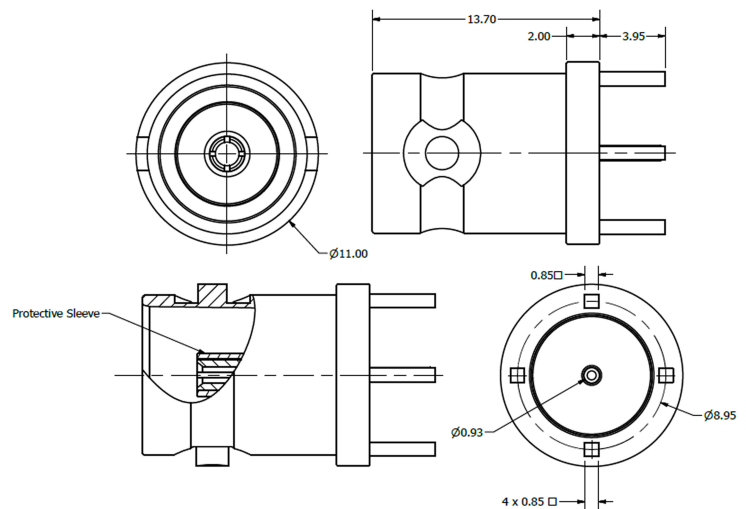

3G SDI

CoaxVision™

