

Ø11.00

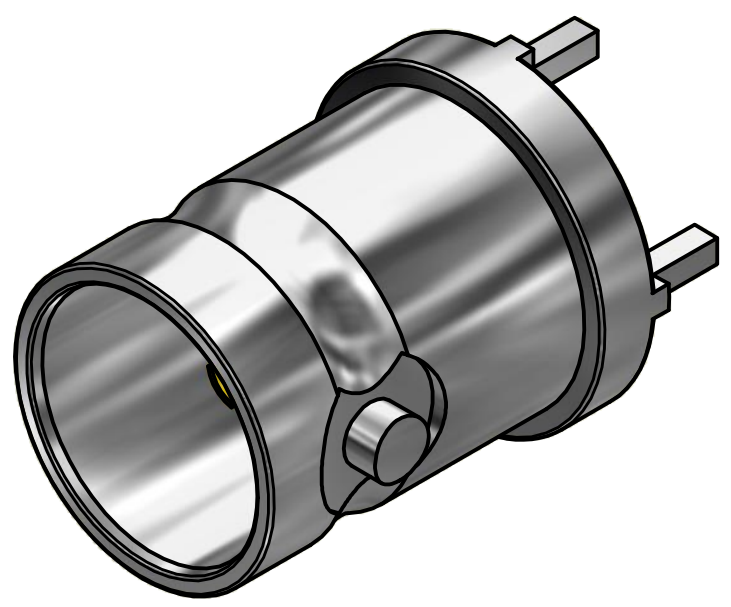
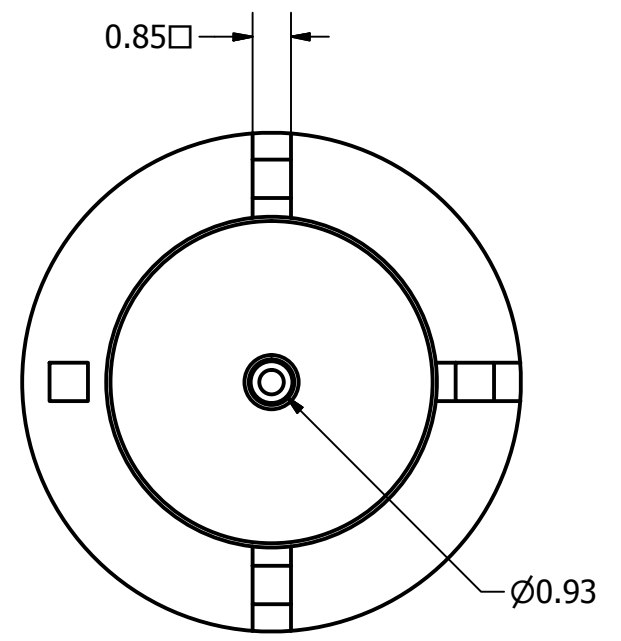
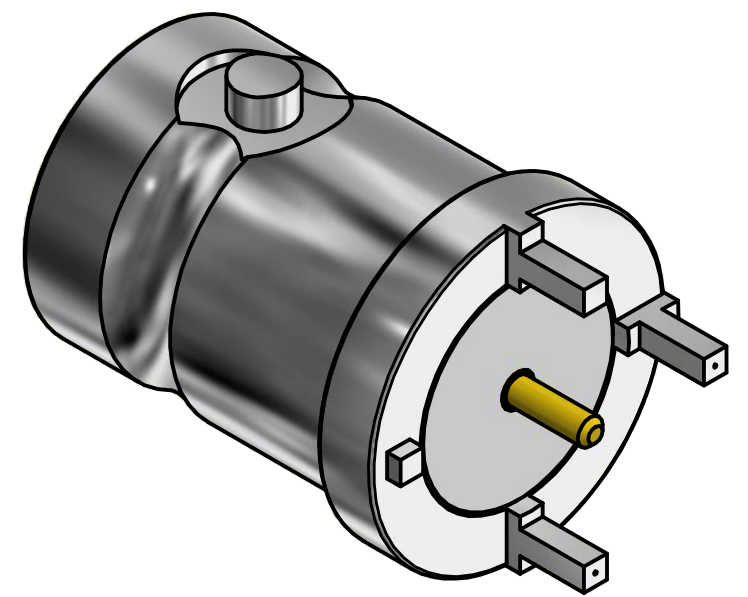
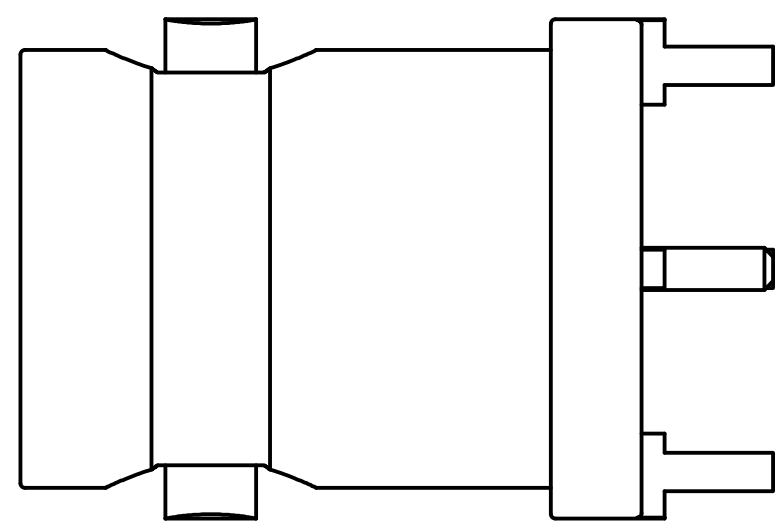
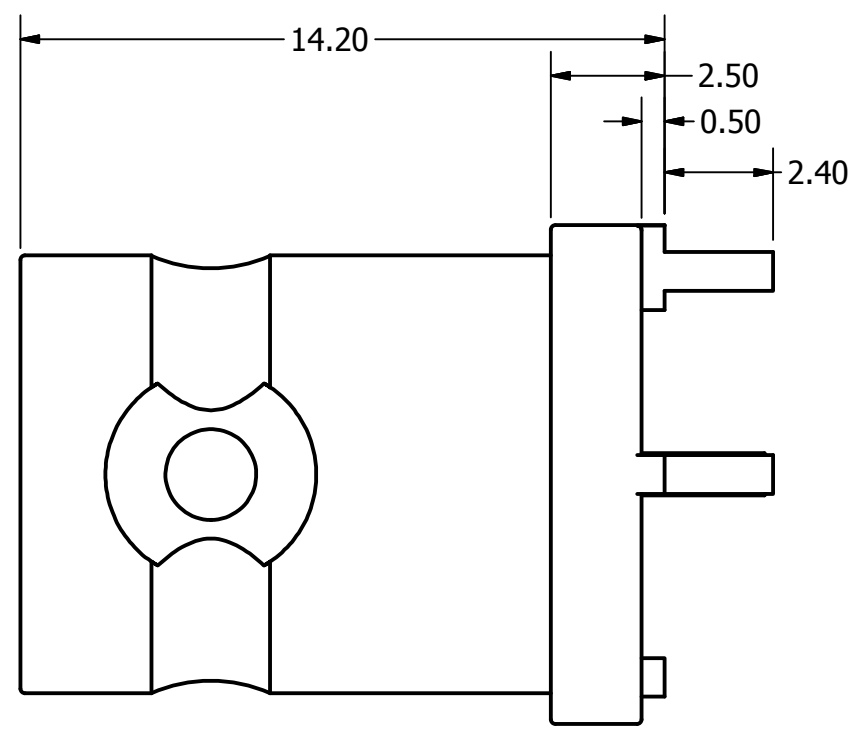

REVISION HISTORY			
REV	DESCRIPTION	DATE	APPROVED
1.0	Origin	21/01/2011	PF
1.1	SMT Leg Added	21/01/2011	PF
1.2	Part Number Issued	11/10/2012	PF

Status: WorkInProgress	Material: Brass/PTFE/PhosBronz	Finish: NI/ /Au	X.X - +0.5 X.XX - +0.05 X.XXX- +0.02	DO NOT SCALE	
	Designed by Peter Fayers	Checked by	Approved by	Date	©2011
					12/10/2006
					A3
	C.E.I. Ltd		This document and all the data contained herein is and shall remain the property of Cambridge Electronic Ind. Ltd and may not be used or copied for any purpose whatsoever without the written permission or Cambridge Electronic Ind. Ltd.		
			Top Entry 3G BNC PiP Compliant		
			C-SX-118	Issue 1.2	Sheet 1 / 3

Electrical:

Impedance	75 Ohms
Freq Range	0-3.0GHz
Working Voltage	500 Vrms
Dielectric withstanding voltage	1500 Vrms
Reflection Factor (VSWR)	1.02 Max DC-1.5GHz 1.10 Max 1.5GHz-3.0GHz
Contact Resistance	Centre Contact 1.5 m Ohm Outer Contact 1.0m Ohm
Insulation Resistance	> 5000 Meg Ohm

Materials

Centre Pin	Phosphor Bronze /10u" Au
Metal Parts	Brass/Ni
Insulators	PTFE

Environmental:

Temp Range:	-65 to +85°C
Mating cycles:	250
Vibration:	MIL-STD-202 Method 204 test condition B
Salt Spray:	MIL-STD-202 Method 101 test condition B

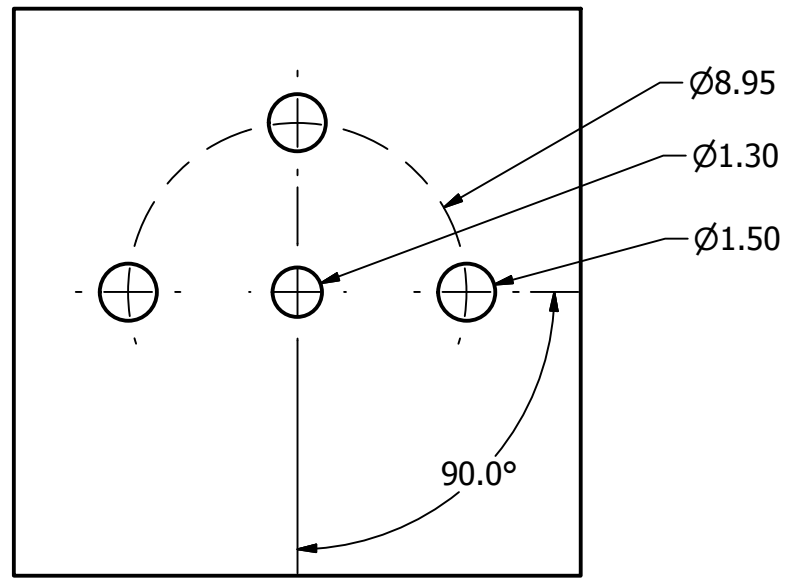
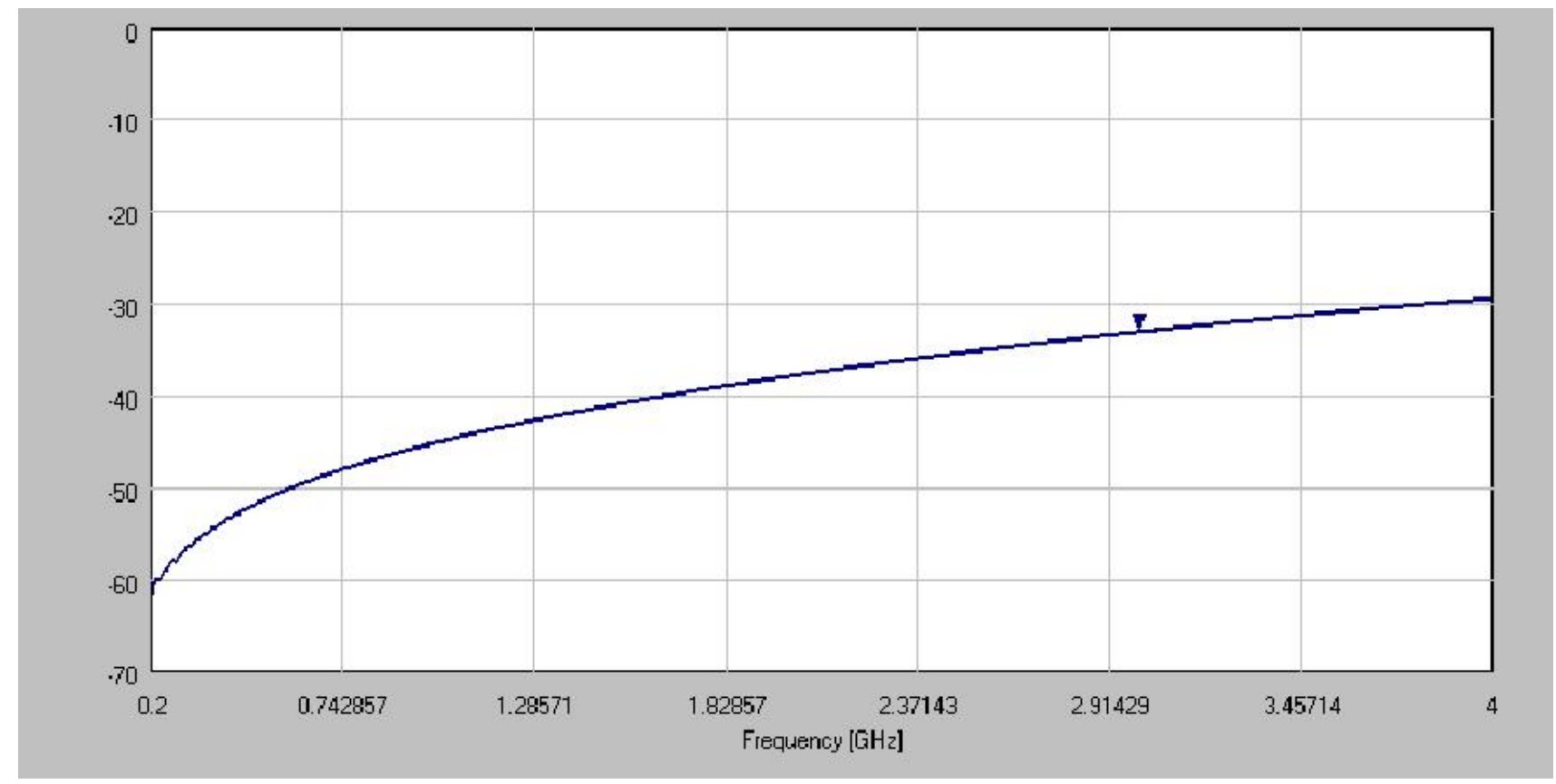



PCB Footprint

Status: WorkInProgress	Material:	Finish:	X.X - +0.5 X.XX - +0.05 X.XXX- +0.02	DO NOT SCALE		
	Designed by Peter Fayers	Checked by	Approved by	Date	©2011	Date 12/10/2006
						A3
	C.E.I. Ltd		This document and all the data contained herein is and shall remain the property of Cambridge Electronic Ind. Ltd and may not be used or copied for any purpose whatsoever without the written permission of Cambridge Electronic Ind. Ltd.			Top Entry 3G BNC PiP Compliant
			C-SX-118	Issue 1.2	Sheet 2 / 3	

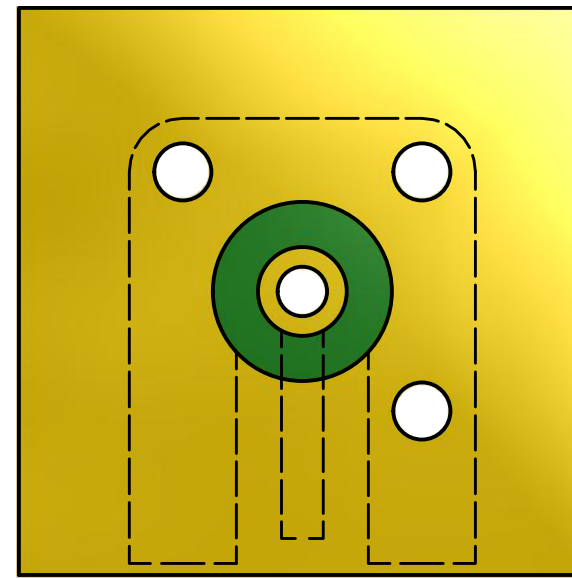
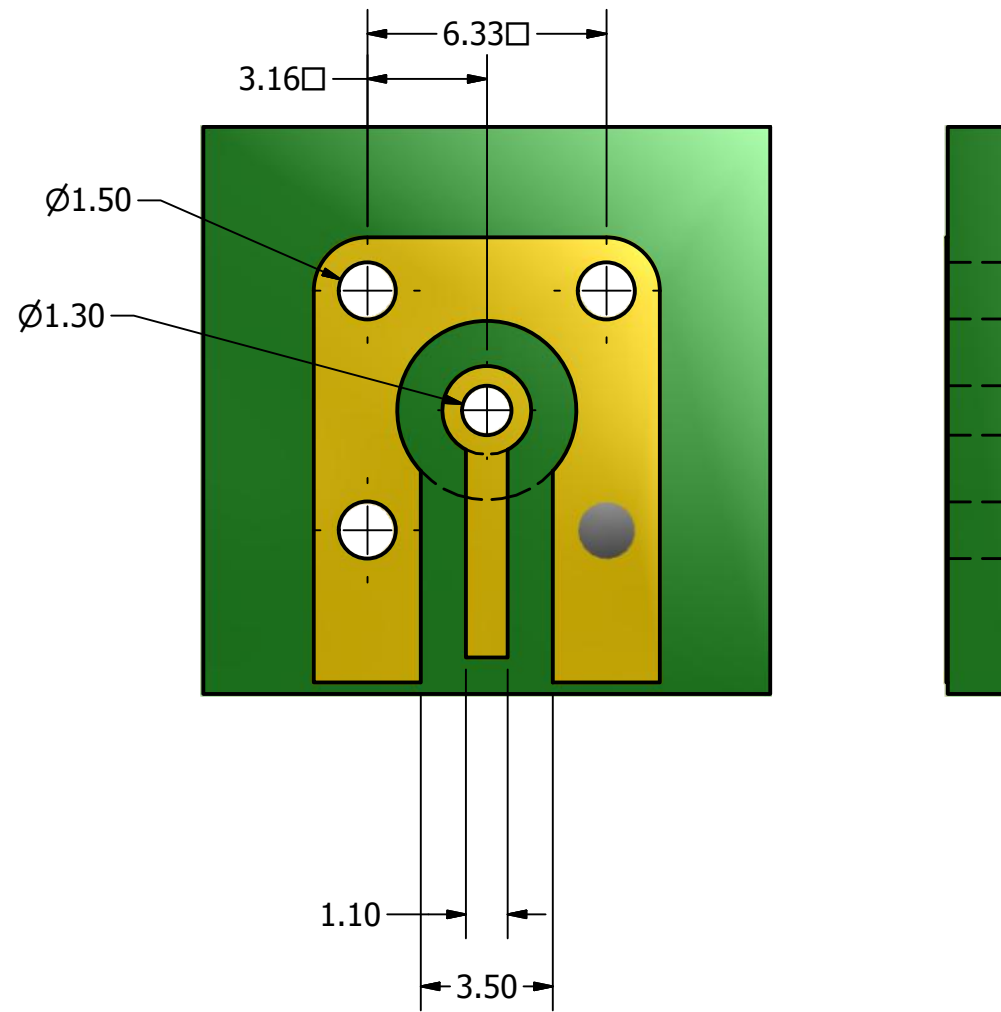
PCB Layout



PCB Top Copper

Status: WorkInProgress	Material: 1.6mm FR4 DS	Finish: 1oz Cu Plate	X.X - +0.5 X.XX - +0.05 X.XXX - +0.02	DO NOT SCALE		
	Designed by Peter Fayers	Checked by	Approved by	Date	©2011	Date 12/10/2006
	C.E.I. Ltd		This document and all the data contained herein is and shall remain the property of Cambridge Electronic Ind. Ltd and may not be used or copied for any purpose whatsoever without the written permission of Cambridge Electronic Ind. Ltd.			
			Top Entry 3G BNC PiP Compliant			Issue 1.2
C-SX-118						