

6GHz DIN 1.0 / 2.3 Coaxial Connectors

Top Entry PCB Mounted Connector (Long Body)

Part Number C-SX-103

General Description

The C-SX-103 is a top entry PCB mounted, long body connector which conforms to the standard of SMPTE ST 2081-1, allowing bit-rates of 5.94Gbit/s over a single coaxial connection. The 8mm pitch of the connector enables double wiring densities and is optimised for use in 6G HD-SDI applications.

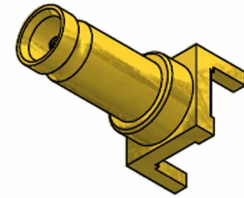

Electrical Specification

Impedance:	75Ω
Frequency Range:	0-6GHz
Working Voltage:	250Vrms
Dielectric Withstanding Voltage:	750Vrms
Reflection Factor (V_{SWR}):	1.36 ^(max) DC - 3GHz 1.38 ^(max) 3 - 6GHz
Contact Resistance:	Centre contact 4.0mΩ Outer contact 2.5mΩ
Insulation Resistance:	>1000M Ω
Connector Type:	Female
Materials	
Centre Pin:	BeCu / 10 μ" Au
Metal Parts:	Brass / Ni
Insulators:	PTFE
Environmental	
Temp Range:	-65 to +85°C
Mating Cycles:	500
Vibration:	MIL-STD-202 Method 204 test conditions B
Salt Spray:	MIL-STD-202 Method 101 test conditions B

Features

- Meets SMPTE ST 2081-1 Standard
- Optimised for 6G HD-SDI applications
- 8mm pitch can double wiring densities
- Secure latching system compatible with standard 1.0/2.3 connectors

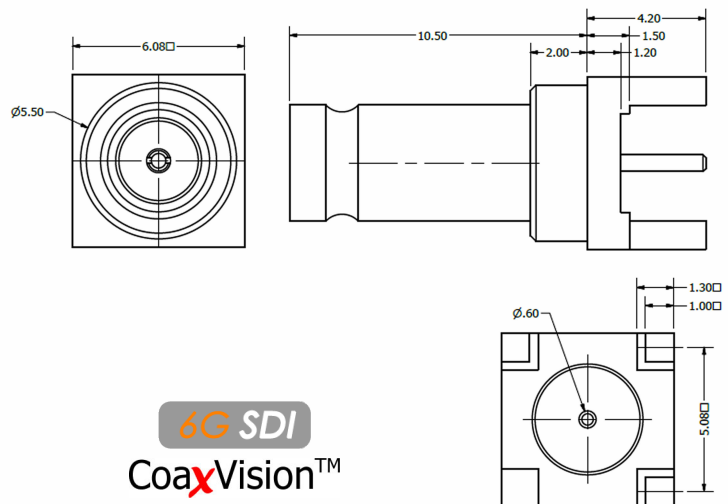

Processing

Maximum wave and hand soldering temperature 265°C

